

ITECH ELECTRONIC

IT2700

Multi-channel Modular Power System



www.itechate.com

 **ITECH**

IT2700

Multi-channel Modular Power System

The IT2700 Series multi-channel modular power system delivers ultra-high power density. A 1U mainframe accepts a mix of test modules—including DC power supply, bidirectional DC source, regenerative DC electronic load, and SMU (precision source meter). Modules support synchronization and sequence control; identical modules can be configured in series or in parallel. Standard interfaces include LAN, USB, CAN, digital I/O, plus free host software. It is ideal for ATE integration across R&D, design verification, and manufacturing of DC-DC converters, telecom power modules, power semiconductors, and 3C products such as smartphones, PCBAs, battery emulation & testing, optoelectronic chips, and power-management ICs.

Features

- Compact size: 1U single unit outputs up to 8 channels
 - Flexible modular system: mix and match various modules
 - 2 mainframes (1U), 4 module types (DC power supply, bidirectional power supply, regenerative load and SMU)*4
 - SMU module supports four-quadrant operation, EIS testing, and offers nA-level accuracy
 - Free PC software PV2700, display 8-channel output
 - Oscilloscope function: Capable of digitizing voltage and current with a frequency of up to 200kHz and a memory depth of 600kpts*1
 - Data logging function: Up to 50kHz sampling rate, and the data can be saved on a USB drive or stored via the host computer.
 - The electrically isolated source load module supports 8 modules in master-slave parallel connection up to 2kW*2
 - Load function: support CC, CV, CP, CR, CC+CV, CR+CV, CP+CV, CC+CR, AUTO,BSIM (battery simulation)
 - Supports automatic switching for CV, CC, and CP, with selectable CC & CV priority, and internal resistance setting.
 - Bidirectional power supply module supports resistance setting in load mode
 - All modules are wide-range modules
 - Single module voltage up to 150V, current up to 50A, power up to 500W
 - Supports synchronous control between different frames, no upper limit of channels
 - Rich trigger output and input, support step trigger output, can trigger other modules (acquisition, oscilloscope, data recording, etc.)
Measurement functions: multi-output/single-output display, supports average, minimum and maximum values of V/I/P, and calculates P, Ah and Wh for all outputs
 - Output functions: list function, arbitrary waveform, sweep, arbitrary wave sequence, constant dwell arbitrary wave, load transient, battery simulation*3, battery test, output on/off serialization, Watchdog, support output coupling
 - Full protection: OVP, UVP, OCP, OPP, OTP, UCP, Foldback, supports protection coupling
 - Modules come with a built-in power relay, supporting reverse polarity protection, leakage prevention, and surge protection
 - Support Web control, use common browser to realize all functions
 - AC input: adaptive 100-380 V ac single phase
 - Built-in LAN, USB-TMC,USB-VCP, CAN, digital I/O, data import and export by USB and supports SCPI and Modbus protocol
- *1 The oscilloscope functions of the 1U mainframe can be operated via PV2700 software.
 *2 One mainframe allows two sets of master-slave parallel connections
 *3 only available for bidirectional power supply modules
 *4 SMU module should be equipped with IT2705 or IT2702 mainframe



DC-DC function verification



Design verification of electronic products



Battery cell simulation and test



Chip test



IT2702 1U frame without front panel



IT2703 1U frame with touch screen

Your Power Testing Solution

IT2700 Multi-channel Modular Power System

Voltage	Current	Power	DC power supply *1	Bidirectional DC power supply *1	Regenerative DC load *1	SMU module *2
±20V	±3A	±20W (2 slots occupied)				IT27814(E)
20V	50A	500W*3 (2 slots occupied)	IT27153/IT27153R	IT27353/IT27353R	IT27553/IT27553R	
30V	15A	200W	IT27134/IT27134R	IT27334/IT27334R	IT27534/IT27534R	
	30A	500W (2 slots occupied)	IT27154/IT27154R	IT27354/IT27354R	IT27554/IT27554R	
60V	10A	200W	IT27135/IT27135R	IT27335/IT27335R	IT27535/IT27535R	
	20A	500W (2 slots occupied)	IT27155/IT27155R	IT27355/IT27355R	IT27555/IT27555R	
150V	5A	200W	IT27137/IT27137R	IT27337/IT27337R	IT27537/IT27537R	
	10A	500W (2 slots occupied)	IT27157/IT27157R	IT27357/IT27357R	IT27557/IT27557R	
IT2702	1U mainframe without front panel (8 slots)					
IT2703	1U mainframe with touch screen (6 slots)					
IT2704	1U mainframe without front panel (8 slots, only available for load modules)					
IT2705	5U mainframe with touch screen (8 slots)					

*1 IT27xxx should be equipped with IT2702/ IT2704/IT2705 ; IT27xxxR should be equipped with IT2703
 *3 20V/50A/500W module could only be equipped with 1U mainframe.

*2 SMU module should be equipped with IT2705 or IT2702 mainframe.

List Sequence

By editing the voltage, current, pulse width and slope of each step, it can generate a variety of complex sequences, help you complete various loading tests and import or export the files.

No.	Curr(A)	Slope(A/ms)	Time(s)	Pace	EOStep	EOStep
1	1.000	0.100	1.000	Auto	On	On
2	2.000	0.100	1.000	Auto	On	Off

- Up to 2000 steps can be set for each list file
- Support infinite loop
- CV, CC, CP, CR mode
- Voltage
- Current
- Slope
- Supports automatic jump or wait for trigger before jump
- Generates pre-step trigger or post-step trigger output

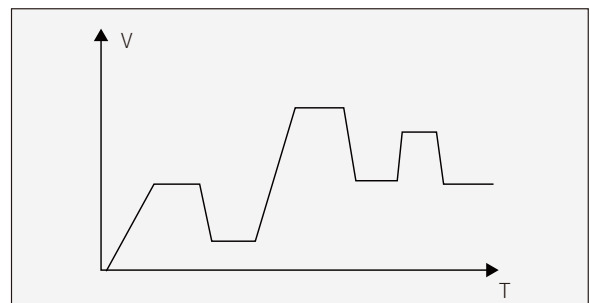

CC&CV Priority

IT2700 power supply and bidirectional power supply modules allow you to select the response priority of the CV/CC loop to determine whether the output is a voltage high-speed mode or a current non-overshoot mode, adapting to different DUTs.

Application: test of diodes, laser diodes, LEDs, power semiconductor components

Your Power Testing Solution

IT2700 Multi-channel Modular Power System

Multiple Operation Modes

IT2700 load provides 10 operating modes. In addition to CC, CV, CR, and CP, it also includes 5 compound modes: CC+CR mode, which is often used in OBC voltage limiting, current limiting characteristic tests, constant voltage accuracy, and constant current accuracy tests to avoid OCP of the OBC. The CR+CV mode is used to simulate LED lights, test the LED power supply, and acquires the current ripple. The CP+CV mode can replace the VON point setting or be used for battery discharge testing, and the voltage setting point can be used as the cut-off voltage. CC+CV mode can be used to simulate batteries, test charging piles or chargers, and limit the maximum load current while CV is working. AUTO mode allows it to be automatically switch between CV, CR, CC and CP modes. When the DUT's protection circuit is damaged, the mode can be automatically switched to avoid DUT damage.

BSIM (Battery Simulation) mode can output a voltage to simulate a battery for testing chargers and other equipment.

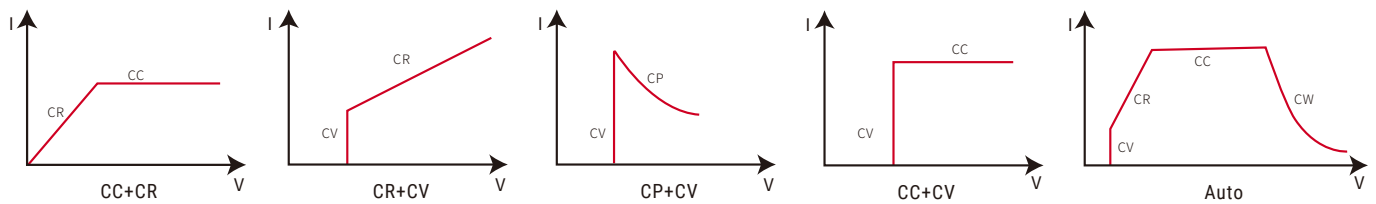

Output On/Off Serialization

The on/off delay function for each output allows you to serialize the on/off of the output.

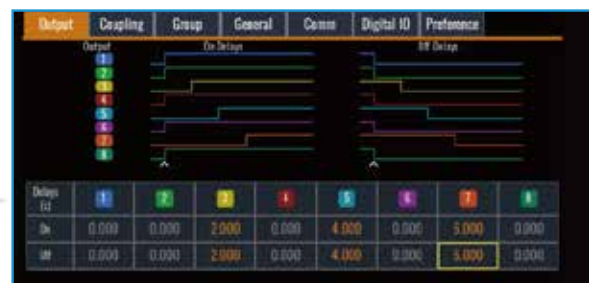
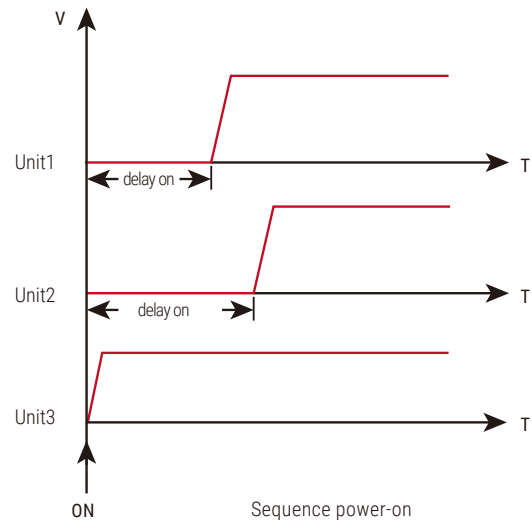
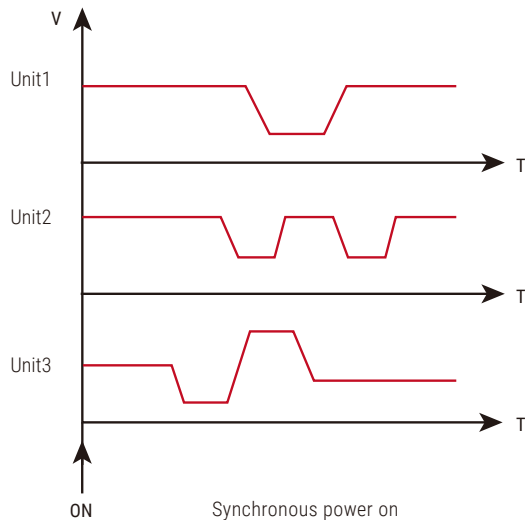

Your Power Testing Solution

IT2700 Multi-channel Modular Power System

Multi-channel Sequence Power-on

Application: chip power-on sequence test/CPU power management chip test

- When multiple power supplies need to output at the same time
- The DUT has multiple inputs and is powered on in a certain timing sequence
- TFT/LCD test, computer PCB test

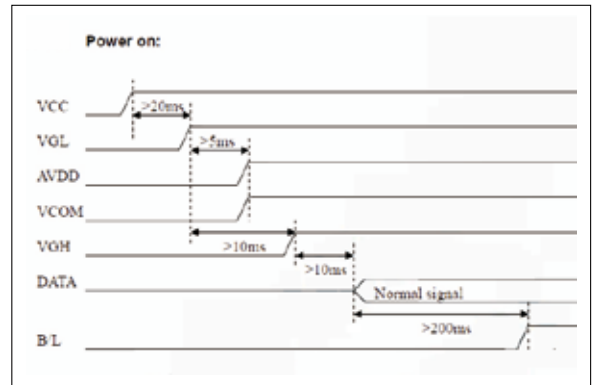

Battery Simulation

IT2700 bidirectional power supply modules have built-in battery simulation function. It can simulate parallel connection of multiple battery modules. You can set the battery's initial state, charge and discharge cutoff state, and you can import battery curves or customize simple battery models, such as PV2700 to simulate multi-channel batteries.

Typical DUTs

Small power tool

Portable electronic devices

Medical equipment

Drones, electric two-wheelers

Outdoor power supply



Power Accumulation Function

IT2700 series uses the power electronic transformation technology on the premise of completing power test to make output energy of DUT recycled and reused. Via fast sampling of voltage and current, the regenerative power value can be observed on the front panel.

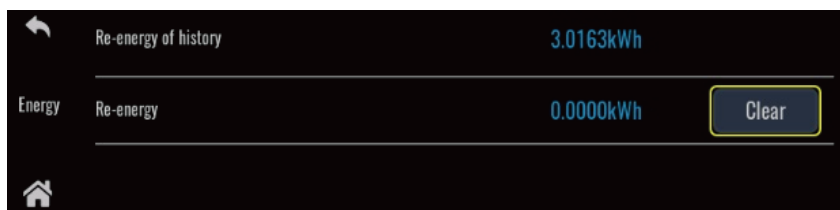

Your Power Testing Solution

IT2700 Multi-channel Modular Power System

DC-DC modules Test

DC-DC modules are widely used in consumer electronics, automotive electronics, industrial equipment, communication systems, energy storage, and new energy sectors.

Test purpose

Low-voltage, high-current, high-voltage and low-current production lines calibrate input and output voltage, current, efficiency and stability

Test method

Select the IT2700 power supply and load modules and connect them to the input and output of the DC-DC modules respectively

Advantages

01 Compacted size with multiple channels

02 Synchronize testing to improve efficiency

03 Flexible combination of modules

04 Power extension by parallel connection, multiple options

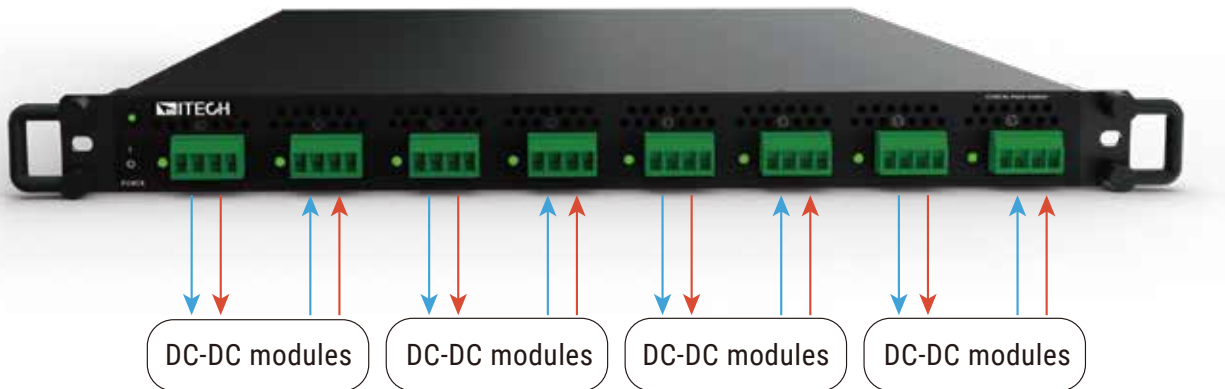

High-speed Dynamic Recovery Time

- IT2700 power module has high-speed dynamic recovery capability. Dynamic recovery time refers to the time required for the power supply output voltage to return to its specified value or steady state when the load changes.
- It maintains stable output, which is particularly important for the test performance of high-precision equipment.
- For high-performance computers, communication equipment and other high-speed electronic products, fast dynamic response helps ensure the best and stable performance of the equipment running at high speeds.
- It has a wider range of applications, such as medical equipment, industrial automation, etc.

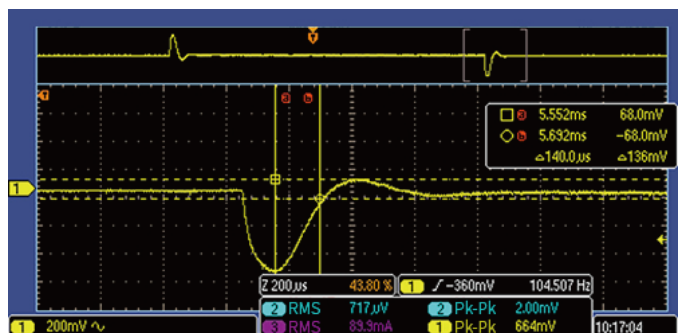

60V full voltage, 50%-100% load (50Hz)
At LOW loop speed, 10%-90% of the steady-state value,
the recovery time is 140μs

Your Power Testing Solution

IT2700 Multi-channel Modular Power System

Max. 240 Channels In a Single Cabinet



240 Channels

Multi-channel control via PC or front panel, single cabinet can output up to 240 channels

Meet the needs for high efficiency, cost reduction and diverse independent testing of production lines

Master-slave parallelization of modules in each unit, synchronization error <math>< 5\mu s</math>

Coupling/Group - Channel Grouping Function

Controlled by LAN, no limit of channels

Group function supports grouping across frames.

Channel Name	Channel	Model	Status	Voltage	Current	Power	PH
Group 1							
PS_1.CH1	1	IT27300	OFF	0.0028V	0.0028A	0.00W	Cur
PS_2.CH1	1	IT27300	OFF	0.0004V	0.0043A	0.00W	Cur
Group 3							
PS_1.CH2	2	IT27100	OFF	0.0028V	0.0028A	0.00W	Cur
PS_2.CH2	2	IT27100	OFF	0.0047V	0.0033A	0.00W	Cur
Group 2							
PS_1.CH3	3	IT27300	OFF	0.0058V	0.0033A	0.00W	Cur
PS_1.CH4	4	IT27300	OFF	0.0009V	0.0047A	0.00W	Cur

Control includes setting voltage and current
|ON by group|Start a function
|Trigger

The coupling function within the frame allows separate settings for output coupling, protection coupling and Inhibit coupling.

Motor Testing - Safety Assurance

Inhibit output prohibition provides more complete interlock linkage protection for automated test systems. When external abnormal signals are received, emergency stop and other abnormal protection can be triggered.

IT2700 is equipped with digital IO interface. When the motor runs abnormally, the motor outputs an abnormal signal (high/low) and transmits it to the inhibit terminal of the digital IO, and at the same time controls the power supply to turn off the output, thereby protecting the DUT.

DUT: DC servo motor



Digital IO Inhibit terminal



Your Power Testing Solution

IT2700 Multi-channel Modular Power System

Multi-/Single-Output Display

PV2700 switches between an 8-output/4-output overview and a single-output detailed view of power analyzer information. All power modules display real-time output voltage and current measurements and status.



Output Name	Mode	Status	Voltage	Current	Power
模块通道_1-CH1	1	Fixed	11.0077V	0.0056A	0.06W
模块通道_1-CH2	2	Fixed	20.0050V	0.0007A	0.17W
模块通道_1-CH3	3	Fixed	21.0050V	0.0015A	0.31W
模块通道_1-CH4	4	Fixed	20.0031V	0.0021A	0.39W
模块通道_2-CH1	5	Fixed	10.0030V	0.0080A	0.79W
模块通道_2-CH2	6	Fixed	20.0048V	0.0001A	0.20W
模块通道_2-CH3	7	Fixed	25.0034V	0.0005A	0.12W

Arbitrary Waveform (Arb)

- Generate waveforms like steps, ramps, trapezoid, user-defined, sine waves, pulses, staircase, exponential.
- Arb Waveform generator enables biased AC (>0V)

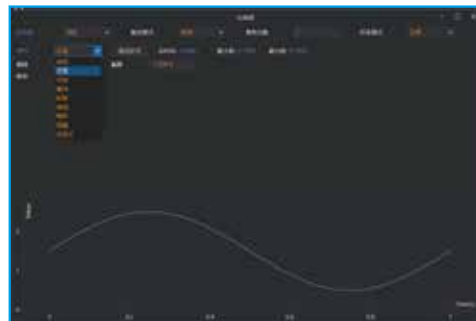
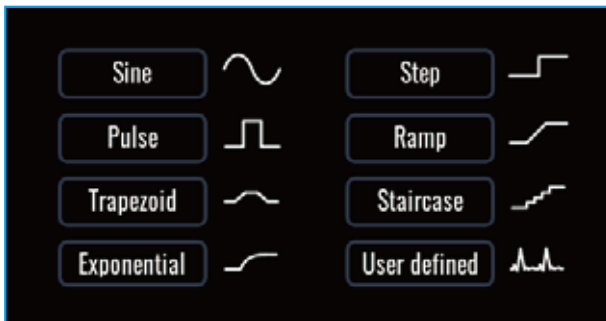

Arbitrary Waveform Sequence (Arb Sequence)

PV2700 can run multiple different arbitrary waveforms one after another, and the ARB sequence can contain any standard ARB type.



Sweeping Sine Wave (Sweep)

- Support sine wave amplitude, bias and frequency sweeps
- Be used to evaluate the stability, efficiency and heating of the DUT
- Available for power supply, bidirectional power supply, and load modules

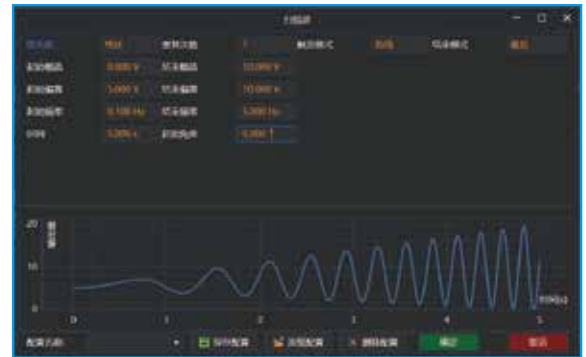

Constant Dwell Arbitrary Waveforms

- Supports users to import captured waveforms, and all points share the same dwell time. CDARB (const dwell arb) is a digital simulation function. Users can replay the sampled voltage or current, power, and resistance waveforms at equal intervals. CDARB supports importing up to 8,000 points with customizable dwell time and can be used in conjunction with the recorder. One for recording data and the other for playback data. Constant dwell time arbitrary waveform, which can be used by users to reproduce arbitrary waveforms.
- Time intervals are equal, and the default setting is the fastest slope.

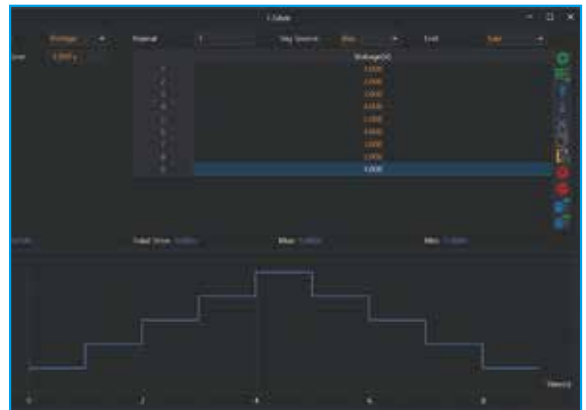

Data Recording Display

PV2700 can record and display the average, minimum and maximum values of voltage, current and power over a period of time. The maximum frequency is 50kHz, and the measurement results can be calculated by adjusting the markers. The measurement results include maximum value, minimum value, average value, peak-to-peak value, ampere-hour, watt-hour and interval time.



Oscilloscope Display

PV2700 can capture up to 16 output voltage and/or current waveforms simultaneously, and can display 6 waveforms simultaneously, with a frequency of up to 200kHz, a maximum of 600kpts., and a resolution of up to 16 bits. The measurement results can be calculated by adjusting the markers. The measurement results include maximum value, minimum value, average value, peak-to-peak value, interval time, etc. It supports common oscilloscope functions such as triggering, rolling and single capture.

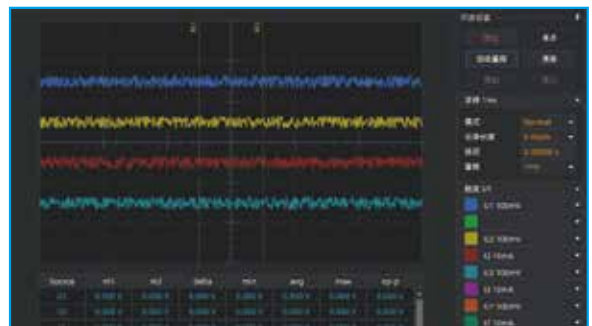

Your Power Testing Solution

IT2700 Multi-channel Modular Power System

48V System - 5G Communication Power Supply, Data Center

- The communications industry uses 48V as the standard voltage
- 5G communications require the use of Massive MIMO technology. The AAU single-sector output power of 5G base stations increases from 4G's 40W and 80W to 200W or even higher.

Advantages tested with IT2700

- IT2700 bidirectional power module can simulate batteries and conduct multi-channel power supply tests
- Regenerative load modules can be used for aging test
- Parallel connection to adapt to more DUTs

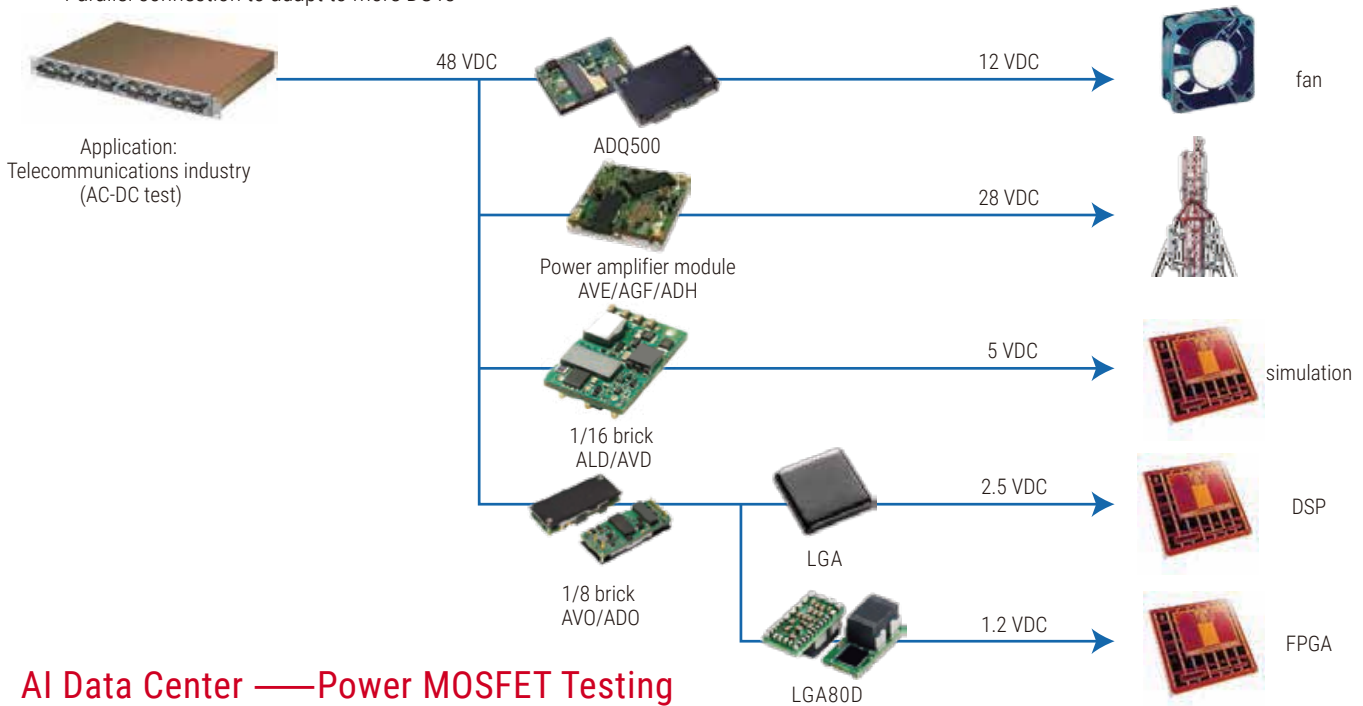

AI Data Center — Power MOSFET Testing

As the demand for cloud computing, artificial intelligence applications, and high-power processors and accelerators continues to grow, data centers continue to evolve to accommodate new high-power needs, including microprocessors, GPUs, FPGAs, and ASICs requiring higher power levels. The power consumption of advanced processors, including Intel's "Sky Lake" and AMD's "Rome", has also risen to 230-300W, and Nvidia's GPU power consumption will climb to about 600W.

Advantages tested with IT2700

- Compact
- Multiple channels
- Current and power extended in parallel/serial connection

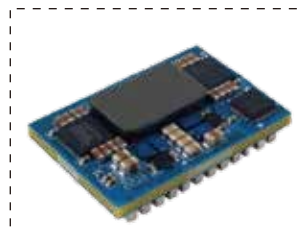

DC/DC power module, up to 300W continuous power
The module supports input voltages up to 60V



24V to 60V, 15A, can be connected in parallel
Electric fuse solution

Advantages Of Production Line Aging Test

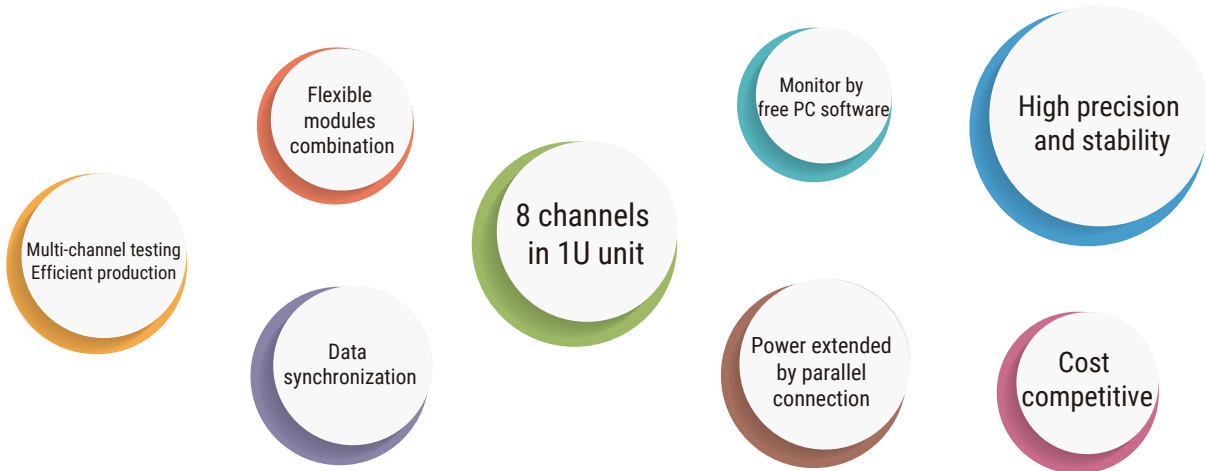

Rack Mount Kit

It can be mounted on standard 19-inch cabinets.

When the IT2702/IT2704 is mounted on an ITECH cabinet, choose the Rack Mount Kit: IT-E157A.

When the IT2702/IT2704 is mounted on a non-ITECH cabinet, choose the accessory: IT-E157B, no tray is required, suitable for cabinets with a mounting depth of 700~907mm.

When the IT2703 is mounted to an ITECH cabinet, select the top shelf kit: IT-E157C.

When IT2703 is mounted to a non-ITECH cabinet, select kit:IT-E157D, no tray required, suitable for cabinets with a mounting depth of 700~907mm..

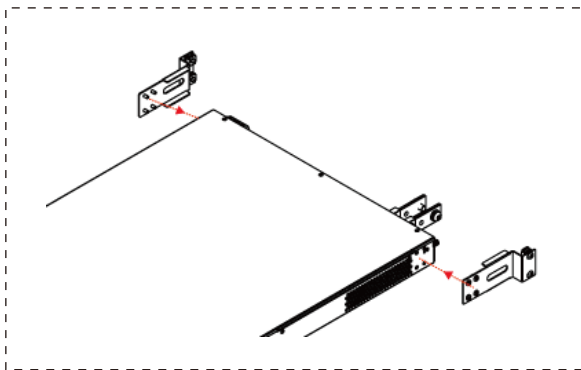

IT-E157A Rear mounting handle for ITECH cabinet.

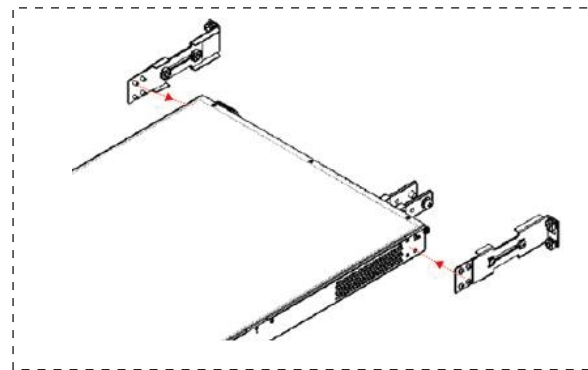

IT-E157B Rear mounting handle for non-ITECH cabinets.

* Note: Front mounting handles are standard for IT2702/IT2704 frames and optional for IT2703, not shown in the picture above.

Your Power Testing Solution

IT2700 Multi-channel Modular Power System

IT2702/IT2704		
AC input	voltage	Single phase 100V~380V
	frequency	50/60Hz
Max. AC apparent power		2.3kVA
Max. AC current ^{*1}		12.5Aac
Max. efficiency		93%
PF		0.99
DC component		≤0.2A
Current harmonic		≤3%
Communication interface		USB/LAN/CAN/Digital IO
Program response		0.1ms
Max. channels		8
Working temperature		0~40°C
Store temperature		-10°C~70°C
Protection level		IP20
Withstand voltage (AC to ground)		3000Vdc/1min
Cooling		fan
Dimension		580mm*437mm*43.5mm
N.W.		9kg

*1 The AC current is limited to 12.5Aac. When the mains voltage is low, power may be limited. For example: single-phase mains, phase voltage 100Vac, the power is: $P = 100\text{Vac} * 12.5\text{Aac} = 1250\text{VA}$

*IT2702 Mainframe can be configured with (bidirectional) power modules or regenerative load modules, whereas IT2704 mainframe supports regenerative load modules only. The two mainframe share the same specifications.

IT2703		
AC input	voltage	Single phase 100V~240V
	frequency	50/60Hz
Max. AC apparent power		1.8kVA
Max. AC current ^{*1}		10Aac
Max. efficiency		92%
PF		0.99
DC component		≤0.2A
Current harmonic		≤3%
Communication interface		USB/LAN/CAN/Digital IO
Program response		0.1ms
Max. channels		6
Display		4.28"
Display resolution		800*200
Working temperature		0~40°C
Store temperature		-10°C~70°C
Protection level		IP20
Withstand voltage (AC to ground)		3000Vdc/1min
Cooling		fan
Dimension		580mm*437mm*43.5mm
N.W.		10kg

*1 The AC current is limited to 10Aac. When the mains voltage is low, power may be limited. For example: single-phase mains, phase voltage 100Vac, the power is: $P = 100\text{Vac} * 10\text{Aac} = 1000\text{VA}$

Your Power Testing Solution

IT2700 Multi-channel Modular Power System

		IT27153/IT27153R	IT27134/IT27134R
Rated values	voltage	0~20V	0~30V
	current	0~50A	0~15A
	power	0~500W	0~200W
	series IR (CV priority)	0~1Ω	0~1Ω
Setup resolution	voltage	0.001V	0.001V
	current	0.001A	0.001A
	power	0.01W	0.01W
	series IR (CV priority)	0.0001Ω	0.0001Ω
Readback resolution	voltage	0.0001V	0.0001V
	current	0.0001A	0.0001A
	power	0.01W	0.01W
Set accuracy	voltage	≤0.02% + 0.02%FS	≤0.02% + 0.02%FS
	current	≤0.05% + 0.05%FS	≤0.05% + 0.05%FS
	power	≤0.1% + 0.2%FS	≤0.1% + 0.2%FS
	series IR (CV priority)	≤1%FS	≤1%FS
Readback accuracy	voltage	≤0.02% + 0.02%FS	≤0.02% + 0.02%FS
	current	≤0.05% + 0.05%FS	≤0.05% + 0.05%FS
	power	≤0.1% + 0.2%FS	≤0.1% + 0.2%FS
Voltage ripple ^{*1}	Vpeak	≤30mVpp	≤30mVpp
	RMS	≤5mV	≤5mV
Setup temperature coefficient	voltage	≤20ppm/°C	≤20ppm/°C
	current	≤30ppm/°C	≤30ppm/°C
Readback temperature coefficient	voltage	≤20ppm/°C	≤20ppm/°C
	current	≤30ppm/°C	≤30ppm/°C
Rise time(no load) ^{*4}	voltage	≤10ms	≤10ms
Rise time(full load)	voltage	≤20ms	≤20ms
Rise time(no load)	voltage	≤0.5s	≤0.5s
Rise time(full load)	voltage	≤50ms	≤10ms
Dynamic response time ^{*2}	voltage	≤1ms	≤1ms
Power regulation	voltage	≤0.005% + 0.005%FS	≤0.005% + 0.005%FS
	current	≤0.015% + 0.015%FS	≤0.015% + 0.015%FS
Load regulation	voltage ^{*3}	≤0.005% + 0.005%FS	≤0.005% + 0.005%FS
	current	≤0.015% + 0.015%FS	≤0.015% + 0.015%FS
Output protection	OCP	51A	15.3A
	OVP	20.4V	30.6V
	OPP	510W	204W
Sense		≤2V	≤3V
Withstand Voltage (DC to ground)		2100V/1min	2100V/1min
Withstand Voltage(AC to DC)		2100V/1min	2100V/1min
Isolation Voltage		800Vdc	600Vdc
Store temperature		-10°C~70°C	-10°C ~ 70°C
Protection level		IP20	IP20
Dimension		320mm*100mm*40mm	320mm*50mm*40mm
N.W.		1.0kg	0.6kg

1. For output voltages ≤ 0.5 V, ripple (peak-to-peak and RMS) doubles

2. From 10% of rated current to 90% of rated current

3. In Sense (remote sense) mode

4. Voltage rise time: 10% → 90% of rated voltage; voltage fall time: 90% → 10% of rated voltage

Your Power Testing Solution

IT2700 Multi-channel Modular Power System

		IT27135/IT27135R	IT27137/IT27137R
Rated values	voltage	0~60V	0~150V
	current	0~10A	0~5A
	power	0~200W	0~200W
	series IR (CV priority)	0~1Ω	0~1Ω
Setup resolution	voltage	0.001V	0.01V
	current	0.001A	0.001A
	power	0.01W	0.01W
	series IR (CV priority)	0.0001Ω	0.0001Ω
Readback resolution	voltage	0.0001V	0.0001V
	current	0.0001A	0.0001A
	power	0.01W	0.01W
Set accuracy	voltage	≤0.02% + 0.02%FS	≤0.02% + 0.02%FS
	current	≤0.05% + 0.05%FS	≤0.05% + 0.05%FS
	power	≤0.1% + 0.2%FS	≤0.1% + 0.2%FS
	series IR (CV priority)	≤1%FS	≤1%FS
Readback accuracy	voltage	≤0.02% + 0.02%FS	≤0.02% + 0.02%FS
	current	≤0.05% + 0.05%FS	≤0.05% + 0.05%FS
	power	≤0.1% + 0.2%FS	≤0.1% + 0.2%FS
Voltage ripple ^{*1}	Vpeak	≤60mVpp	≤150mVpp
	RMS	≤10mV	≤15mV
Setup temperature coefficient	voltage	≤20ppm/°C	≤20ppm/°C
	current	≤30ppm/°C	≤30ppm/°C
Readback temperature coefficient	voltage	≤20ppm/°C	≤20ppm/°C
	current	≤30ppm/°C	≤30ppm/°C
Rise time(no load) ^{*4}	voltage	≤10ms	≤10ms
Rise time(full load)	voltage	≤20ms	≤20ms
Rise time(no load)	voltage	≤0.5s	≤0.5s
Rise time(full load)	voltage	≤10ms	≤10ms
Dynamic response time ^{*2}	voltage	≤1ms	≤1ms
Power regulation	voltage	≤0.005% + 0.005%FS	≤0.005% + 0.005%FS
	current	≤0.015% + 0.015%FS	≤0.015% + 0.015%FS
Load regulation	voltage ^{*3}	≤0.005% + 0.005%FS	≤0.005% + 0.005%FS
	current	≤0.015% + 0.015%FS	≤0.015% + 0.015%FS
Output protection	OCP	10.2A	5.1A
	OVP	61.2V	153V
	OPP	204W	204W
Sense		≤6V	≤15V
Withstand Voltage (DC to ground)		2100V/1min	2100V/1min
Withstand Voltage(AC to DC)		2100V/1min	2100V/1min
Isolation Voltage		600Vdc	600Vdc
Store temperature		-10°C~70°C	-10°C~70°C
Protection level		IP20	IP20
Dimension		320mm*50mm*40mm	320mm*50mm*40mm
N.W.		0.6kg	0.6kg

13 IT2700 Multi-channel Modular Power System

1.For output voltages ≤ 0.5 V, ripple (peak-to-peak and RMS) doubles

2.From 10% of rated current to 90% of rated current

3.In Sense (remote sense) mode

4.Voltage rise time: 10% → 90% of rated voltage; voltage fall time: 90% → 10% of rated voltage

Your Power Testing Solution

IT2700 Multi-channel Modular Power System

		IT27353/IT27353R	IT27334/IT27334R
Rated values	voltage	0~20V	0~30V
	current	-50A~50A	-15A~15A
	power	-500W~500W	-200W~200W
	series IR (CV priority)	0~1Ω	0~1Ω
	load IR (CC priority)	0.01Ω~100Ω	0.02Ω~200Ω
Setup resolution	voltage	0.001V	0.001V
	current	0.001A	0.001A
	power	0.01W	0.01W
	series IR (CV priority)	0.0001Ω	0.0001Ω
	load IR (CC priority)	0.01Ω	0.01Ω
Readback resolution	voltage	0.0001V	0.0001V
	current	0.0001A	0.0001A
	power	0.01W	0.01W
Set accuracy	voltage	≤0.02% + 0.02%FS	≤0.02% + 0.02%FS
	current	≤0.05% + 0.05%FS	≤0.05% + 0.05%FS
	power	≤0.1% + 0.2%FS	≤0.1% + 0.2%FS
	series IR (CV priority)	≤1%FS	≤1%FS
	load IR (CC priority) ^{*1}	(Vin/Rset)*0.5%+0.5%FS	(Vin/Rset)*0.5%+0.5%FS
Readback accuracy	voltage	≤0.02% + 0.02%FS	≤0.02% + 0.02%FS
	current	≤0.05% + 0.05%FS	≤0.05% + 0.05%FS
	power	≤0.1% + 0.2%FS	≤0.1% + 0.2%FS
Voltage ripple ^{*2}	Vpeak	≤30mVpp	≤30mVpp
	RMS	≤5mV	≤5mV
Setup temperature coefficient	voltage	≤20ppm/°C	≤20ppm/°C
	current	≤30ppm/°C	≤30ppm/°C
Readback temperature coefficient	voltage	≤20ppm/°C	≤20ppm/°C
	current	≤30ppm/°C	≤30ppm/°C
Rise time(no load) ^{*5}	voltage	≤10ms	≤10ms
Rise time(full load)	voltage	≤20ms	≤20ms
Rise time(no load)	voltage	≤10ms	≤10ms
Rise time(full load)	voltage	≤10ms	≤10ms
Dynamic response time ^{*3}	voltage	≤1ms	≤1ms
Power regulation	voltage	≤0.005% + 0.005%FS	≤0.005% + 0.005%FS
	current	≤0.015% + 0.015%FS	≤0.015% + 0.015%FS
Load regulation	voltage ^{*4}	≤0.005% + 0.005%FS	≤0.005% + 0.005%FS
	current	≤0.015% + 0.015%FS	≤0.015% + 0.015%FS
Output protection	OCP	-51A or 51A	-15.3A or 15.3A
	OVP	20.4V	30.6V
	OPP	-510W or 510W	-204W or 204W
Sense		≤2V	≤3V
Withstand Voltage (DC to ground)		2100V/1min	2100V/1min
Withstand Voltage(AC to DC)		2100V/1min	2100V/1min
Isolation Voltage		800Vdc	600Vdc
Store temperature		-10°C~70°C	-10°C~70°C
Protection level		IP20	IP20
Dimension		320mm*100mm*40mm	320mm*50mm*40mm
N.W.		1.0kg	0.6kg

1.Resistor accuracy – voltage/current ≥ 10% FS

2.For voltages ≤ 0.5 V, ripple (peak-to-peak and RMS) doubles

3.From 10% rated current to 90% rated current

4.In Sense mode

5.Voltage rise time: 10% to 90% of rated voltage; voltage fall time: 90% to 10% of rated voltage

Your Power Testing Solution

IT2700 Multi-channel Modular Power System

		IT27335/IT27335R	IT27337/IT27337R
Rated values	voltage	0~60V	0~150V
	current	-10A~10A	-5A~5A
	power	-200W~200W	-200W~200W
	series IR (CV priority)	0~1Ω	0~1Ω
	load IR (CC priority)	0.06Ω~600Ω	0.3Ω~3000Ω
Setup resolution	voltage	0.001V	0.01V
	current	0.001A	0.001A
	power	0.01W	0.01W
	series IR (CV priority)	0.0001Ω	0.0001Ω
	load IR (CC priority)	0.01Ω	0.01Ω
Readback resolution	voltage	0.0001V	0.0001V
	current	0.0001A	0.0001A
	power	0.01W	0.01W
Set accuracy	voltage	≤0.02% + 0.02%FS	≤0.02% + 0.02%FS
	current	≤0.05% + 0.05%FS	≤0.05% + 0.05%FS
	power	≤0.1% + 0.2%FS	≤0.1% + 0.2%FS
	series IR (CV priority)	≤1%FS	≤1%FS
	load IR (CC priority) ^{*1}	(Vin/Rset)*0.5%+0.5%FS	(Vin/Rset)*0.5%+0.5%FS
Readback accuracy	voltage	≤0.02% + 0.02%FS	≤0.02% + 0.02%FS
	current	≤0.05% + 0.05%FS	≤0.05% + 0.05%FS
	power	≤0.1% + 0.2%FS	≤0.1% + 0.2%FS
Voltage ripple ^{*2}	Vpeak	≤60mVpp	≤150mVpp
	RMS	≤10mV	≤15mV
Setup temperature coefficient	voltage	≤20ppm/°C	≤20ppm/°C
	current	≤30ppm/°C	≤30ppm/°C
Readback temperature coefficient	voltage	≤20ppm/°C	≤20ppm/°C
	current	≤30ppm/°C	≤30ppm/°C
Rise time(no load) ^{*5}	voltage	≤10ms	≤10ms
Rise time(full load)	voltage	≤20ms	≤20ms
Rise time(no load)	voltage	≤10ms	≤10ms
Rise time(full load)	voltage	≤10ms	≤10ms
Dynamic response time ^{*3}	voltage	≤1ms	≤1ms
Power regulation	voltage	≤0.005% + 0.005%FS	≤0.005% + 0.005%FS
	current	≤0.015% + 0.015%FS	≤0.015% + 0.015%FS
Load regulation	voltage ^{*4}	≤0.005% + 0.005%FS	≤0.005% + 0.005%FS
	current	≤0.015% + 0.015%FS	≤0.015% + 0.015%FS
Output protection	OCP	-10.2A or 10.2A	-5.1A or 5.1A
	OVP	61.2V	153V
	OPP	-204W or 204W	-204W or 204W
Sense		≤6V	≤15V
Withstand Voltage (DC to ground)		2100V/1min	2100V/1min
Withstand Voltage(AC to DC)		2100V/1min	2100V/1min
Isolation Voltage		600Vdc	600Vdc
Store temperature		-10°C~70°C	-10°C ~ 70°C
Protection level		IP20	IP20
Dimension		320mm*50mm*40mm	320mm*50mm*40mm
N.W.		0.6kg	0.6kg

15 IT2700 Multi-channel Modular Power System

1. Resistor accuracy – voltage/current ≥ 10% FS

2. For voltages ≤ 0.5 V, ripple (peak-to-peak and RMS) doubles

3. From 10% rated current to 90% rated current

4. In Sense mode

5. Voltage rise time: 10% to 90% of rated voltage; voltage fall time: 90% to 10% of rated voltage

Your Power Testing Solution

IT2700 Multi-channel Modular Power System

		IT27553/IT27553R	IT27534/IT27534R
Rated values	voltage	0.05V~20V	0.03V~30V
	current	0~50A	0~15A
	power	0~500W	0~200W
	resistance *	0.01Ω~100Ω	0.02Ω~200Ω
	MOV.	0.8V at 50A	0.3V at 15A
	input leakage current	0.001A	0.001A
Setup resolution	voltage	0.001V	0.001V
	current	0.001A	0.001A
	power	0.01W	0.01W
	resistance	0.01Ω	0.01Ω
Readback resolution	voltage	0.0001V	0.0001V
	current	0.0001A	0.0001A
	power	0.01W	0.01W
Set accuracy	voltage	≤0.02% + 0.02%FS	≤0.02% + 0.02%FS
	current	≤0.05% + 0.05%FS	≤0.05% + 0.05%FS
	power	≤0.1% + 0.2%FS	≤0.1% + 0.2%FS
	resistance * ¹	(Vin/Rset)*0.5%+0.5%FS	(Vin/Rset)*0.5%+0.5%FS
Readback accuracy	voltage	≤0.02% + 0.02%FS	≤0.02% + 0.02%FS
	current	≤0.05% + 0.05%FS	≤0.05% + 0.05%FS
	power	≤0.1% + 0.2%FS	≤0.1% + 0.2%FS
Setup temperature coefficient	voltage	≤20ppm/°C	≤20ppm/°C
	current	≤30ppm/°C	≤30ppm/°C
Readback temperature coefficient	voltage	≤20ppm/°C	≤20ppm/°C
	current	≤30ppm/°C	≤30ppm/°C
Dynamic response time	rise time	25A/ms	15A/ms
	fall time	25A/ms	15A/ms
	dynamic frequency	500Hz	500Hz
Power regulation	voltage	≤0.005% + 0.005%FS	≤0.005% + 0.005%FS
	current	≤0.015% + 0.015%FS	≤0.015% + 0.015%FS
Load regulation	voltage * ²	≤0.005% + 0.005%FS	≤0.005% + 0.005%FS
	current	≤0.015% + 0.015%FS	≤0.015% + 0.015%FS
Short circuit current	current	52.5A	15.75A
Input protection	OCP	51A	15.3A
	OVP	20.4V	30.6V
	OPP	510W	204W
Input OVP		21V	31.5V
Sense		≤2V	≤3V
Withstand Voltage (DC to ground)		2100V/1min	2100V/1min
Withstand Voltage(AC to DC)		2100V/1min	2100V/1min
Isolation Voltage		800Vdc	600Vdc
Store temperature		-10°C~70°C	-10°C~70°C
Protection level		IP20	IP20
Dimension		320mm*100mm*40mm	320mm*50mm*40mm
N.W.		1.0kg	0.6kg

*1 resistance accuracy-voltage and current not less than 10%FS

*2 sense mode

Your Power Testing Solution

IT2700 Multi-channel Modular Power System

		IT27535/IT27535R	IT27537/IT27537R
Rated values	voltage	0.06V~60V	0.150V~150V
	current	0~10A	0~5A
	power	0~200W	0~200W
	resistance *	0.06Ω~6000Ω	0.3Ω~3000Ω
	MOV.	0.6V at 10A	1.5V at 5A
	input leakage current	0.001A	0.001A
Setup resolution	voltage	0.001V	0.01V
	current	0.001A	0.001A
	power	0.01W	0.01W
	resistance	0.01Ω	0.01Ω
Readback resolution	voltage	0.0001V	0.0001V
	current	0.0001A	0.0001A
	power	0.01W	0.01W
Set accuracy	voltage	≤0.02% + 0.02%FS	≤0.02% + 0.02%FS
	current	≤0.05% + 0.05%FS	≤0.05% + 0.05%FS
	power	≤0.1% + 0.2%FS	≤0.1% + 0.2%FS
	resistance *1	(Vin/Rset)*0.5%+0.5%FS	(Vin/Rset)*0.5%+0.5%FS
Readback accuracy	voltage	≤0.02% + 0.02%FS	≤0.02% + 0.02%FS
	current	≤0.05% + 0.05%FS	≤0.05% + 0.05%FS
	power	≤0.1% + 0.2%FS	≤0.1% + 0.2%FS
Setup temperature coefficient	voltage	≤20ppm/°C	≤20ppm/°C
	current	≤30ppm/°C	≤30ppm/°C
Readback temperature coefficient	voltage	≤20ppm/°C	≤20ppm/°C
	current	≤30ppm/°C	≤30ppm/°C
Dynamic response time	rise time	10A/ms	5A/ms
	fall time	10A/ms	5A/ms
	dynamic frequency	500Hz	500Hz
Power regulation	voltage	≤0.005% + 0.005%FS	≤0.005% + 0.005%FS
	current	≤0.015% + 0.015%FS	≤0.015% + 0.015%FS
Load regulation	voltage *2	≤0.005% + 0.005%FS	≤0.005% + 0.005%FS
	current	≤0.015% + 0.015%FS	≤0.015% + 0.015%FS
Short circuit current	current	10.5A	5.25A
Input protection	OCP	10.2A	5.1A
	OVP	61.2V	153V
	OPP	204W	204W
	Input OVP	63V	156V
Sense		≤6V	≤15V
Withstand Voltage (DC to ground)		2100V/1min	2100V/1min
Withstand Voltage(AC to DC)		2100V/1min	2100V/1min
Isolation Voltage		600Vdc	600Vdc
Store temperature		-10°C~70°C	-10°C ~70°C
Protection level		IP20	IP20
Dimension		320mm*50mm*40mm	320mm*50mm*40mm
N.W.		0.6kg	0.6kg

*1 resistance accuracy-voltage and current not less than 10%FS

*2 sense mode

Your Power Testing Solution

IT2700 Multi-channel Modular Power System

		IT27814				IT27814E				
Rated range	voltage	±6 V		±20 V		±6 V		±20 V		
	current	±3 A		±1 A		±3 A		±1 A		
	power	±20 W		±20 W		±20 W		±20 W		
Load regulation (voltage)	range	±6 V		±20 V		±6 V		±20 V		
	accuracy	150 μV		400 μV		600 μV		2 mV		
Load regulation (current)	range	10mA	100mA	1A	3A	10mA	10mA	1A	3A	
	accuracy	1 μA	1 μA	50 μA	100 μA	3 μA	3 μA	200 μA	400 μA	
Voltage setting accuracy	range	±6 V		±20 V		±6 V		±20 V		
	resolution	6 μV		20 μV		210 μV		700 μV		
	accuracy	≤0.015%+300 μV		≤0.015%+1 mV		≤0.02%+1 mV		≤0.02%+3 mV		
Current setting accuracy	range	10 mA	100 mA	3 A		10 mA	100 mA	3 A		
	resolution	0.1 μA	1 μA	10 μA		1 μA	10 μA	300 μA		
	accuracy	≤0.025% + 5 μA	≤0.025% + 10 μA	≤0.03% + 250 μA		≤0.05% + 6 μA	≤0.05% + 50 μA	≤0.05% + 1.5 mA		
Voltage measurement accuracy	range	±6 V		±20 V		±6 V		±20 V		
	resolution	6 μV		20 μV		210 μV		700 μV		
	accuracy	≤0.015%+300 μV		≤0.015%+1 mV		≤0.02%+1 mV		≤0.02%+3 mV		
Current measurement accuracy	range	10 μA	1 mA	100 mA	3 A	10 μA	1 mA	100 mA	3 A	
	resolution	100 pA	10 nA	1 μA	10 μA	1 nA	100 nA	10 μA	300 μA	
	accuracy	≤0.025% + 8 nA	≤0.025% + 100 nA	≤0.025% + 10 μA	≤0.03% + 250 μA	≤0.05% + 8 nA	≤0.05% + 400 nA	≤0.05% + 40 μA	≤0.05% + 1.2 mA	
Internal resistance setting accuracy	range	±6 V		±20 V		±6 V		±20 V		
	resolution	0.25 mΩ		0.5 mΩ		0.5 mΩ		0.5 mΩ		
	Setting range (R)	- 40 mΩ ~ 1 Ω		- 40 mΩ ~ 1 Ω		- 40 mΩ ~ 1 Ω		- 40 mΩ ~ 1 Ω		
	Setting accuracy	0.1% + 1.5 mΩ		0.1% + 3 mΩ		0.1% + 1.5 mΩ		0.1% + 3 mΩ		
Voltage loop speed	The voltage loop has four speed settings: Low, High1, High2, and High3. The corresponding rise times are measured with load capacitances of 0μF / 0μF / 1μF / 7μF respectively.									
		Low	High1	High2	High3	Low	High1	High2	High3	
	20V Range (0-10V)	250 μs	20 μs	20 μs	120 μs	250 μs	25 μs	35 μs	120 μs	
	6V Range (0-4V)	200 μs	15 μs	15 μs	40 μs	160 μs	20 μs	25 μs	50 μs	
		Rise time (≤0.1%)								
	20V Range (0-10V)	450 μs	75 μs	65 μs	220 μs	450 μs	75 μs	65 μs	220 μs	
6V Range (0-4V)	450 μs	55 μs	45 μs	120 μs	450 μs	55 μs	45 μs	120 μs		
Current loop speed	range	10 mA	100 mA	1 A	3 A	10 mA	100 mA	1 A	3 A	
	Rise time (10%-90%)	5 μs	4.5 μs	3.7 μs	3.7 μs	10 μs	10 μs	14 μs	15 μs	
	Rise time (≤0.1%)	30 μs	30 μs	30 μs	30 μs	30 μs	30 μs	30 μs	30 μs	
Other characteristics										
Voltage output noise (10 Hz to 20 MHz)	12mVp-p / 1.2mVrms									
CV mode dynamic response recovery time	Under sense mode, with a 150μF load capacitor (ESR = 50mΩ), current rise time is 10μs									
	20V range, 0.8A current step, voltage recovers to ±10mV within ≤35μs				20V range, 0.8A current step, voltage recovers to ±20mV within ≤40μs					
	6V range, 1.4A current step, voltage recovers to ±20mV within ≤35μs				6V range, 1.4A current step, voltage recovers to ±20mV within ≤55μs					
CC mode dynamic response recovery time	3A setting, voltage step 1-4V, current recovers to 5mA in 16μs				3A setting, voltage step 1-4V, current recovers to 5mA in 35μs					
	1A setting, voltage step 0.5-0V, current recovers to 10mA in 10μs				1A setting, voltage step 0.5-0V, current recovers to 10mA in 25μs					

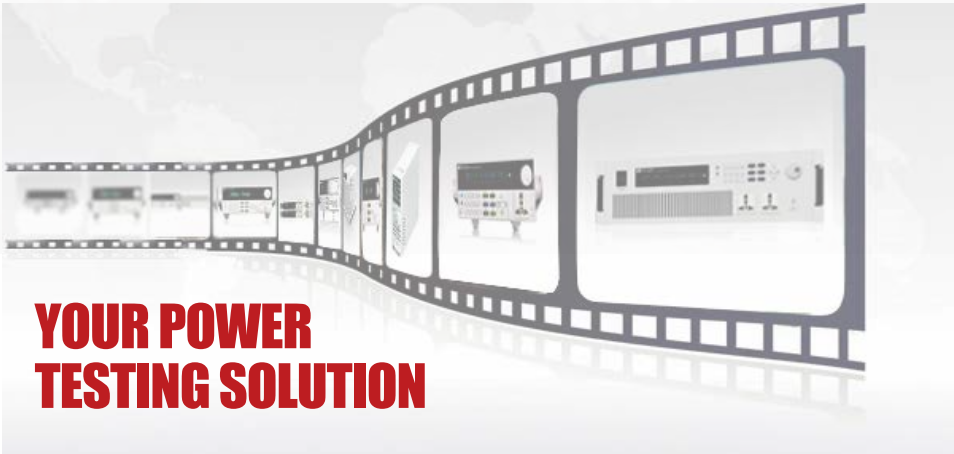
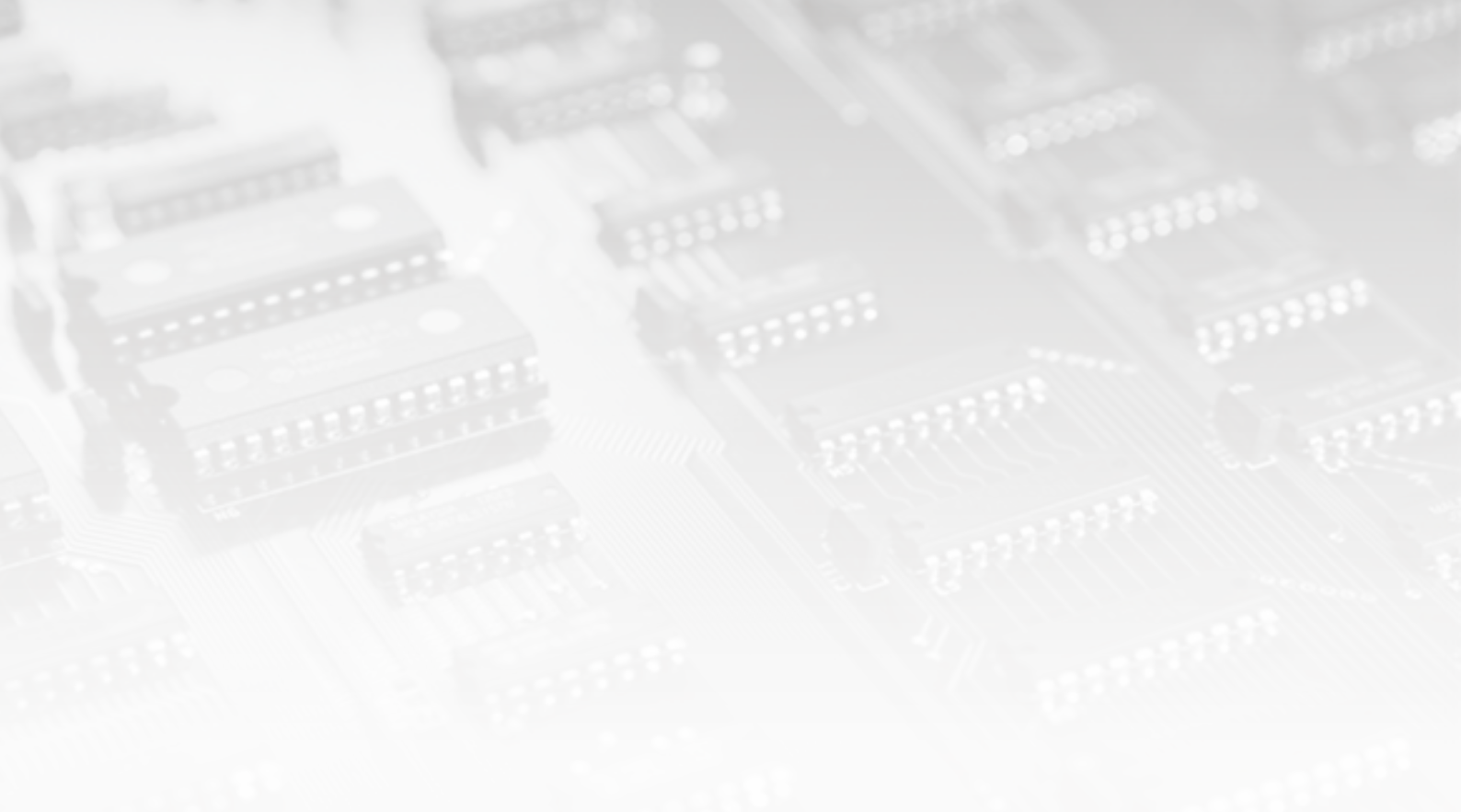

This information is subject to change without notice. For more information, please contact ITECH.

Taipei

Add: No.918, Zhongzheng Rd., Zhonghe Dist., New Taipei
City 235, Taiwan
Web: www.itechate.com
TEL: +886-3-6684333
E-mail: info@itechate.com



ITECH Web



ITECH Facebook



ITECH LinkedIn